

**STANDARD:**

- Investment Casting Body & Cap
- Blow-Out Proof Stem
- Full Port 2-PC Design Standard Style
- Refine Stem Packing Available
- Pressure Balance Hole in Ball Solt(as request)
- Locking Device Handle Available
- Design Standard:ASME B16.34
- Wall Thickness:ASME B16.34,GB 12224
- Several Handle Material Available
- All Kind of Screws Available
- Inspection Standard:API598

Pressure Temperature Compare



Technical Data			
Test Pressure	Shell Test	9.0	MPA
	Tightness Test	7.50	
	Gas-Tightness Test	0.8	
Max Working temperature		-20°C~+160°C	
Applicable Medium:Water,Oil,Gas,Acid			

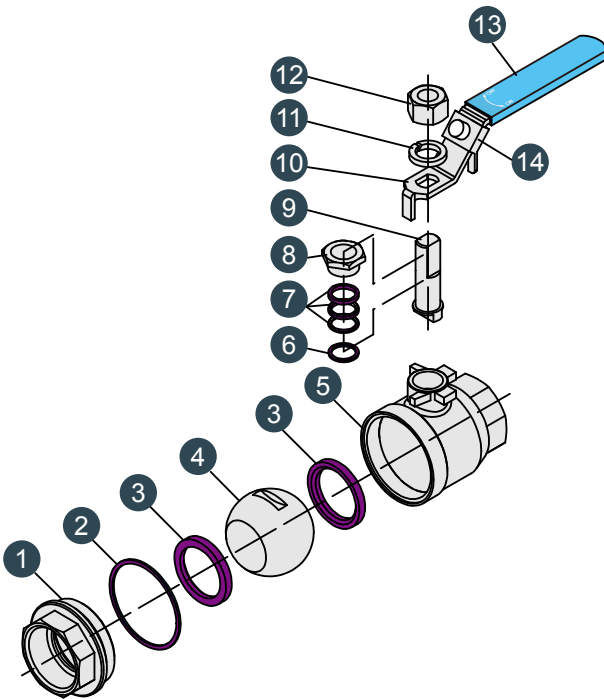

No.	PARTS	MATERIAL		
1	Cap	CF8M	CF8	WCB
2	Gasket	PTFE		R-PTFE
3	Ball Seat	PTFE		R-PTFE
4	Ball	SS316		SS304
5	Body	CF8M	CF8	WCB
6	Thrust Washer	PTFE		R-PTFE
7	Stem Packing	PTFE		R-PTFE
8	Stop Nut	SS304		SS201
9	Stem	SS316		SS304
10	Handle	SS304		SS201
11	Spring Washer	SS304		SS201
12	Nut	SS304		SS201
13	Handle Cover	Plastic		
14	Locking Device	SS304		SS201

PPL & PEEK High temperature ball seat available

Unit:mm

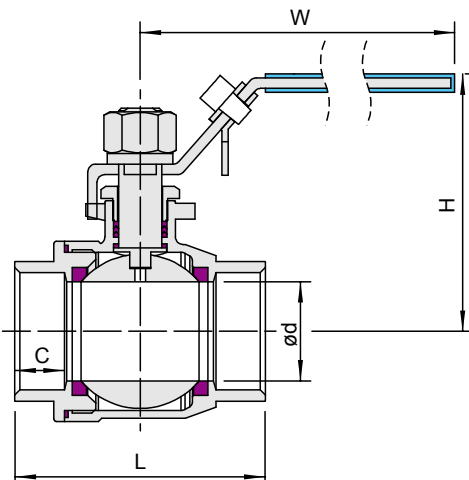

SIZE	d	L	H	W	C	TORQUE N.M
1/4"	10	51	50	75	10	3
3/8"	10	52	52	90	10.5	3
1/2"	15	63	58	95	13.5	4
3/4"	20	73	65	95	14	5.5
1"	25	83.5	70	111	16.5	6
1 1/4"	32	96	80	124	19	8
1 1/2"	38	106	90	139	19	10
2"	48	121	99	152	23.5	18
2 1/2"	65	156	123	200	31.5	25
3"	76	177	135	200	32	32
4"	98	220	160	250	44	45