

**STANDARD:**

- Investment Casting Body & Cap
- Blow-Out Proof Stem
- Full Port 2000PSI 120Bar
- Pressure Blank Hole in Ball Solt(as request)
- ISO5211 Mounting Pad Top Flange
- Locking Device Handle Available
- Design Standard:ASME B16.34
- Wall Thickness:ASME B16.34,GB 12224
- Several Handle Material Available
- All Kind of Screws Available
- Inspection Standard:API598

Pressure Temperature Compare

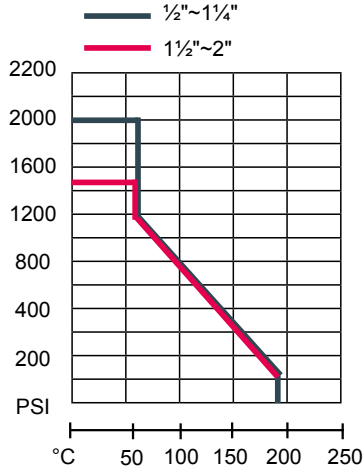

Technical Data			
Test Pressure	Shell Test	18.0	MPA
	Tightness Test	12.50	
	Gas-Tightness Test	0.8	
Max Working temperature		-20°C~+160°C	
Applicable Medium:Water,Oil,Gas,Acid			

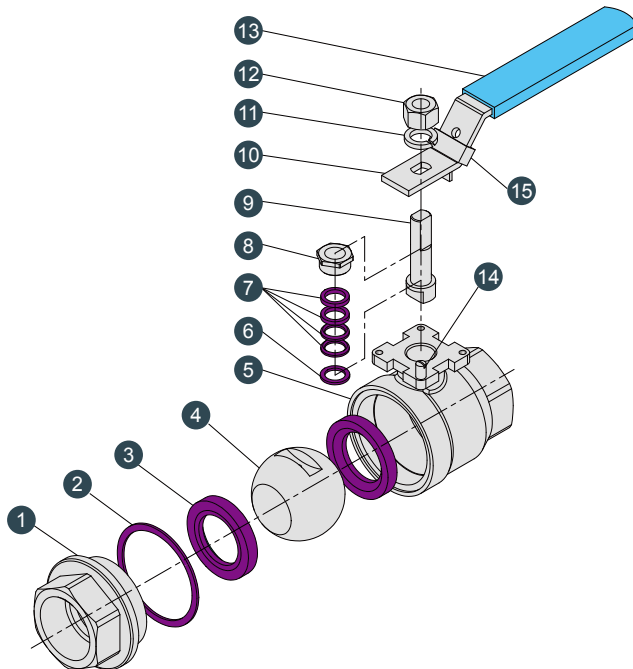

No.	PARTS	MATERIAL		
1	Cap	CF8M	CF8	WCB
2	Gasket	PTFE	R-PTFE	
3	Ball Seat	PTFE	R-PTFE	
4	Ball	SS316	SS304	
5	Body	CF8M	CF8	WCB
6	Thrust Washer	PTFE	R-PTFE	
7	Stem Packing	PTFE	R-PTFE	
8	Stop Nut	SS304	SS201	
9	Stem	SS316	SS304	
10	Handle	SS304	SS201	
11	Spring Washer	SS304		
12	Nut	SS304	SS201	
13	Handle Cover	Plastic		
14	Position Pin	SS304	SS201	
15	Locking Device	SS304	SS201	

PPL & PEEK High temperature ball seat available

Unit:mm

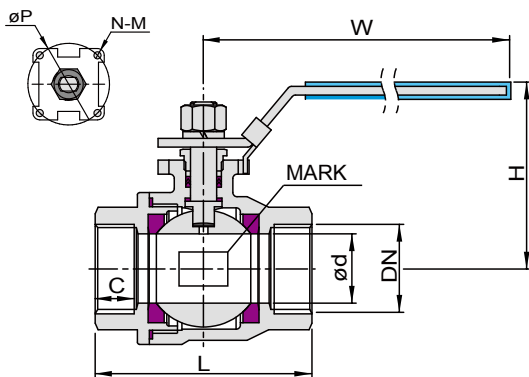

SIZE	d	L	H	W	P	N-M	C	TORQUE N.M
1/2"	15	65	60	120	36	4-M5	13.5	4
3/4"	20	73	65	120	36	4-M5	14	7.5
1"	25	86	75	160	42	4-M5	16.5	12.5
1 1/4"	32	100	83	160	42	4-M5	19	23
1 1/2"	38	115	99	200	50	4-M6	19	30
2"	48	135	115	200	50	4-M6	23.5	50